



SURVEY REPORT OF 2011 VAN EARTHQUAKE IN TURKEY

Koichi KUSUNOKI¹, Akira TASAI², Yo HIBINO³, Hidekazu WATANABE⁴,
Muneyoshi NUMADA⁵, Mucip TAPAN⁶ and Alper ILKI⁷

ABSTRACT: On October 23, 2011 at 10:41:21 UTC, an intense earthquake ($M_w=7.1$ according to USGS) occurred in eastern Turkey. Another earthquake ($M_w=5.6$ according to USGS) occurred around Van city on November 9, 2011 which also caused the collapse of buildings weakened by the first shock. AIJ and JAEE organized a survey team after the events. The team was dispatched to Van and Ercis cities, Turkey, and conducted initial damage assessment in the damaged area with the survey groups from Yuzuncu Yil University, Bogazici University and mainly Istanbul Technical University. This report outlines the findings obtained from the survey of the damaged area.

Key Words: 2011 Van earthquake, damage reconnaissance, R/C buildings, Masonry buildings, Damage classification

INTRODUCTION

On October 23, 2011 at 10:41:21 UTC, an intense earthquake ($M7.1$) occurred in eastern Turkey (Location: 38.691°N, 43.497°E). The focal depth was 16 km (USGS). The epicenter was 16 km (9 miles) NNE from Van city. Another earthquake ($M5.6$) occurred around Van city on November 9, 2011 which also caused the collapse of buildings weakened by the earthquake on October 23. These continuous seismic motions caused widespread destruction in the area of Ercis-Tabanlı-Van. Many inhabitants in the affected areas lost their houses by seismic motions. The death toll was confirmed respectively 604 and 40 people by the earthquake of Oct. 23rd and November 9th in damaged area according to Disaster and Emergency Management Presidency of Turkey (AFAD). A total of 2,300 people were seriously injured or slightly injured. 14,618 buildings and houses were damaged in this area (USGS).

OUTLINE OF THE INVESTIGATION

After the events, Architectural Institute of Japan (AIJ) and Japan Association of Earthquake

¹ Associate Professor, Institute of Urban Innovation, Yokohama National University, Japan

² Professor, Institute of Urban Innovation, Yokohama National University, Japan

³ Assistant Professor, Structural Engineering Research Center, Tokyo Institute of Technology, Japan

⁴ Assistant Professor, Department of Architecture, Graduate School of Engineering,
Hiroshima University, Japan

⁵ Research Associate, The International Center for Urban Safety Engineering, Institute of Industrial
Science, The University of Tokyo, Japan

⁶ Assistant Professor, Faculty of Engineering & Architecture, Department of Civil Engineering,
Yuzuncu Yil University, Turkey

⁷ Professor, Civil Engineering Faculty, Istanbul Technical University, Turkey

Engineering (JAEE) decided to dispatch a reconnaissance team to the affected area collaborating with Turkish reconnaissance team. The members of the team are listed on Table 1. The team started reconnaissance at December 22nd in central area of Van city, and continued until 27th. Reconnaissance was conducted in Erciş area at December 23rd, where is about 70km north from central Van city and severely affected by the earthquakes of Oct. 23rd. The route of the investigation is shown in Figure 1. Investigated buildings are listed below;

Table 1 Members of reconnaissance team

Koichi Kusunoki	AIJ team leader, Yokohama National University, Japan
Akira Tasai	Yokohama National University, Japan (AIJ)
Yo Hibino	Tokyo Institute of Technology, Japan (AIJ)
Muneyoshi Numada	Institute of Industrial Science, The Univ. of Tokyo, Japan (JAEE)
Hidekazu Watanabe	Hiroshima University, Japan (AIJ)
Alper Ilki	Istanbul Technical University (ITU)
Cem Demir	Istanbul Technical University (ITU)
Mustafa Comert	Istanbul Technical University (ITU)
Mucip Tapan	Yuzuncu Yil University
Kutay Orakcal	Bogazici University (BU)
Mubin Uslu	Istanbul Technical University (ITU)
Hamdi Ates	Istanbul Technical University (ITU)
Ahmet Sahin	Istanbul Technical University (ITU)



Figure 1 Route of the investigation

- Nineteen apartment buildings (7 were investigated in detail)
- Five schools
- Five commercial buildings
- Five masonry residential houses
- Five mosques
- Four public buildings (all were investigated in details)
- Four factories
- Four bridges
- One airport terminal
- One non-engineered reinforced concrete residential house

BUILDING DAMAGES

In this section, outline of the damages of 4 buildings drawn in Figure 1 and other typical damages observed in the affected area are shown.

School building in Alakoy

The school building shown in Photo 1 is located in Alakoy and consisted of structurally independent two reinforced concrete buildings stand side by side: three-story and two-story reinforced concrete buildings. The three-story building was severely damaged.

The second floor plan of the buildings and damage patterns are shown in Figure 2. The details of damage are written beneath the column depicted by rectangular in Figure 2. The three-story building has four spans in the longitudinal direction and three bays in the transverse direction, and those of span lengths are shown in Figure 2. The columns are arranged in the same direction, except the column on the west side, beside the entrance indicated as a triangle symbol. The typical geometry of cross section of the columns shown in Figure 2 has eighteen $\phi 16$ plain bars, a $\phi 10$ plain bar hoop spaced at 250 mm approximately, and 20 mm of concrete cover. A clear height of 2.1 m at the second floor was assumed.



(a) Front view



(b) North-west side of view

Photo 1 Overview of building

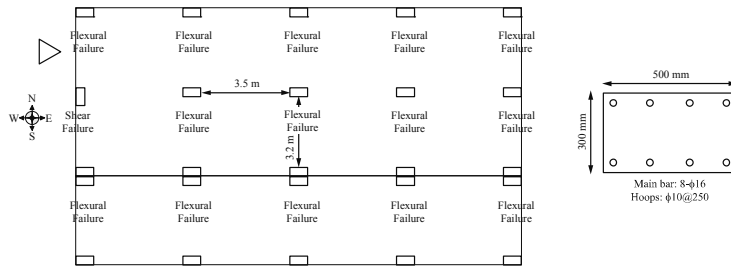

Figure 2 Second floor plan and damage pattern of columns

Photo 2(a) shows details of a west side column failed in shear. Concrete of the core was splitted off by the shear crack and the longitudinal reinforcement buckled. All the columns failed in flexure in north-south direction except the west side column as shown in Photo 2(b). Photo 3 shows the expansion joint between two buildings and approximately gap of 60 mm at the top of the second floor observed. The unreinforced concrete masonry wall was damaged and had several shear cracks of non-structural components.



(a) West side column failing in shear



(b) Column flexural yielding at the top

Photo 2 Details of damaged columns



Photo 3 Expansion joint between two buildings

The story shear strength of the three-story building was calculated by assuming the ultimate shear strength of columns at the second floor. The ultimate flexural strength and shear strength of the columns was calculated by Eq. (1), (2) and Eq. (3), respectively, and the minimum of those strengths was used as the ultimate shear strength of the column.

$$M_u = 0.8 \cdot a_t \cdot \sigma_y \cdot D + 0.5 \cdot N \cdot D \cdot \left(1 - \frac{N}{b \cdot D \cdot \sigma_B} \right) \quad (1)$$

$$Q_{mu} = 2M_u / h \quad (2)$$

$$Q_{su} = \left\{ \frac{0.068 p_t^{0.23} \cdot (\sigma_B + 18)}{M / (Q \cdot d) + 0.12} + 0.85 \sqrt{p_w \cdot \sigma_{wy}} + 0.1 \sigma_0 \right\} \cdot b \cdot j \quad (3)$$

where a_t : total area of main bars in tensile (mm^2), σ_y : yield strength of main bar (MPa, assumed as 220MPa), D : height of column (mm), N : axial force (N, calculated from floor area supported by the column and 12kN/m^2 as unit weight), b : width of column (mm), σ_B : concrete strength (MPa, assumed as 16MPa by concrete core tests), h : clear height of column (mm), $p_t = 100a_t / (b \cdot D)$, $M / (Q \cdot d)$: assumed as $h / (2 \cdot d)$ if $M / (Q \cdot d) < 1$ then $M / (Q \cdot d) = 1$, if $M / (Q \cdot d) > 3$ then $M / (Q \cdot d) = 3$, $p_w = a_w / (b \cdot s)$, a_w : total area of hoop (mm^2), s : hoop pitch, σ_{wy} : yielding strength of hoop (MPa, assumed as 220MPa), $\sigma_0 = N / (b \cdot D)$, and $j := (7/8)d$.

The calculated ultimate strengths of the columns are listed on Table 2. The story shear strength of the floor is calculated as 674.4 kN, and the base shear strength coefficient, C_B is calculated by using the floor weight of two floors (2,688 kN) as 0.25. The west side end column was judged as failing in flexure as shown in Table 2, hence material property or bar arrangement detail are need to be discussed.

Table 2 Calculated strengths

$b \times D$ (mm×mm)	Q_{mu} (kN)	Q_{su} (kN)	Q_{su}/Q_{mu}	Q_u (kN)	Number of column	ΣQ_u (kN)
500×300	45.2	134	2.96	45.2	14	632.8
300×500	41.6	170	4.08	41.6	1	41.6
Story shear strength (kN)						674.4

School building in Gedikbulak

The building is three stories reinforced concrete building which is located at a village apart around 2 kilometers from the epicenter of the main-shock (October 23rd). The building was constructed in sometime from 1980 to 1990. All stories completely collapsed by the earthquake as shown in Photo 4. Fortunately no students and no teachers were killed, because the earthquake occurred on holiday. Since no structural and construction information is available, unquestionable reason of the collapse is unknown. Many beams and columns were observed to be separated at the join as shown in Photo 5(a). The reasons of such premature failures at joints were because of short anchorage length of beam main rebar to column and lack of confinement in the joint, as shown in Photo 5(b). The photograph also shows the ineffective anchorage length in the bottom bars of beam, which demonstrates the structural design and/or detailing was conducted only for vertical load, not for seismic load. Thus, the building must have collapsed by separation of beams and columns at every joint one after another during the earthquake, without providing enough resistance of structural members.



(a) West side of view



(b) East side of view

Photo 4 Overview of building



(a) Separation between beam and column



(b) Anchorage failure of beam main rebar

Photo 5 Details of damaged beam-column joint

Damage classification of four apartment buildings (Bahcelievler Sitesi A-D)

Four apartment buildings as shown in Photo 6 were investigated. The buildings are six stories reinforced concrete buildings, and their layout is shown in Figure 3. The first and second floor plan with the damage level in the longitudinal direction of structural members of Building A, B, C and D are shown in Figure 4 to Figure 7, respectively. Photo 7(a) shows details of shear failure at the top of a south side column. The beam-column joint failure was observed in the south-east corner of Building C as shown in Photo 7(b).

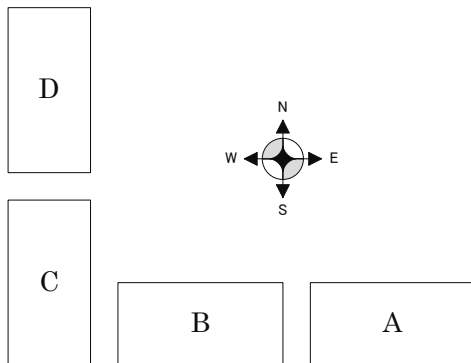

Figure 3 Building layout



Photo 6 North-east side view of the buildings

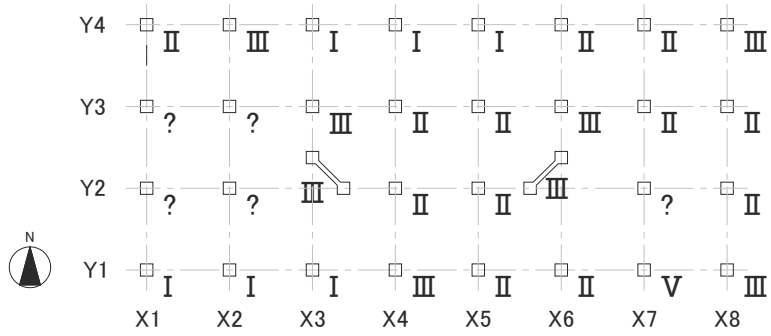

Figure 4 Second floor plan and damage level of structural members (Building A)

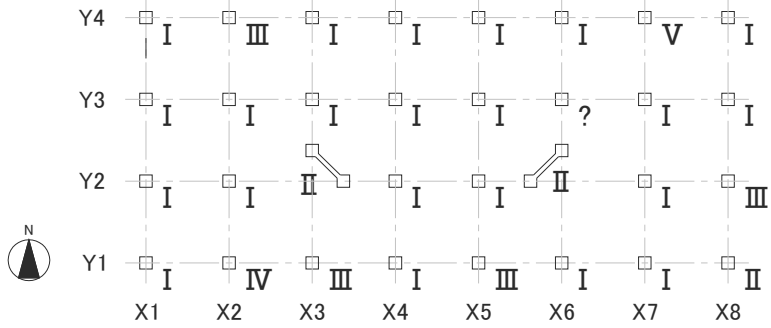

Figure 5 First floor plan and damage level of structural members (Building B)

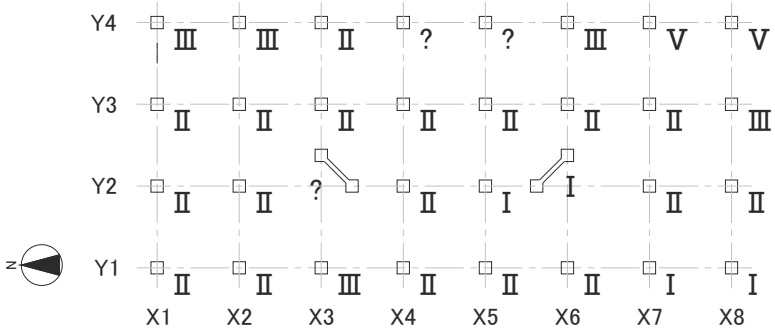

Figure 6 Second floor plan and damage level of structural members (Building C)

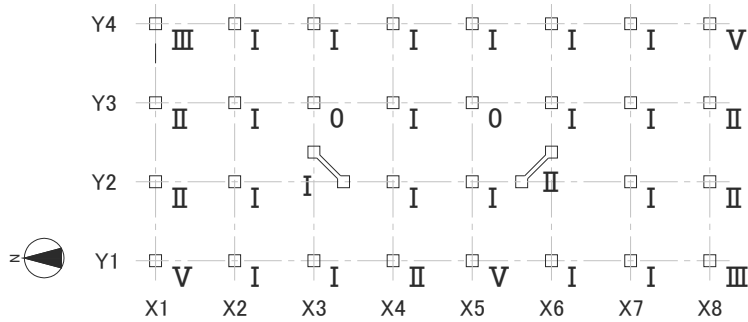

Figure 7 First floor plan and damage level of structural members (Building D)



(a) shear failure of south side column of Building A (damage level V)



(b) beam-column joint failure (south-east corner of Building C)

Photo 7 Details of damages

The damage levels of the buildings in the longitudinal direction are classified in Table 3 using the damage evaluation method (The Building Disaster Prevention Association of Japan 2001). In the method, the damage level of building is evaluated using the residual seismic performance ratio, which is calculated according to damage level of vertical structural members and the failure mode of members. In the methods 1 and 2, the columns are assumed to fail in flexure and shear, respectively. It can be seen from Table 3 that the damage classification using the method 2 is more severe than using the method 1 in Buildings B and D.

Table 3 Damage classification of the buildings

	Damage evaluation method	
	Method 1 (Flexural failure)	Method 2 (Shear failure)
Building A	Severe damage	Severe damage
Building B	Moderate damage	Severe damage
Building C	Moderate damage	Moderate damage
Building D	Minor damage	Moderate damage

Building of Department of Water Management (Devlet Su isleri Binail)

The building has three stories and one semibasement floor. South-east side of the building is shown in Photo 8. The plan of the main building is shown in Figure 4. The building is separated into three portions. They are not connected but have gap between buildings. Building A was constructed in 1975 with round bar and hand-mixed concrete. Building B and C were constructed in 1993 with round bar and hand-mixed concrete. Building D is new and was constructed in 2009 with deformed bar and ready-mixed concrete.

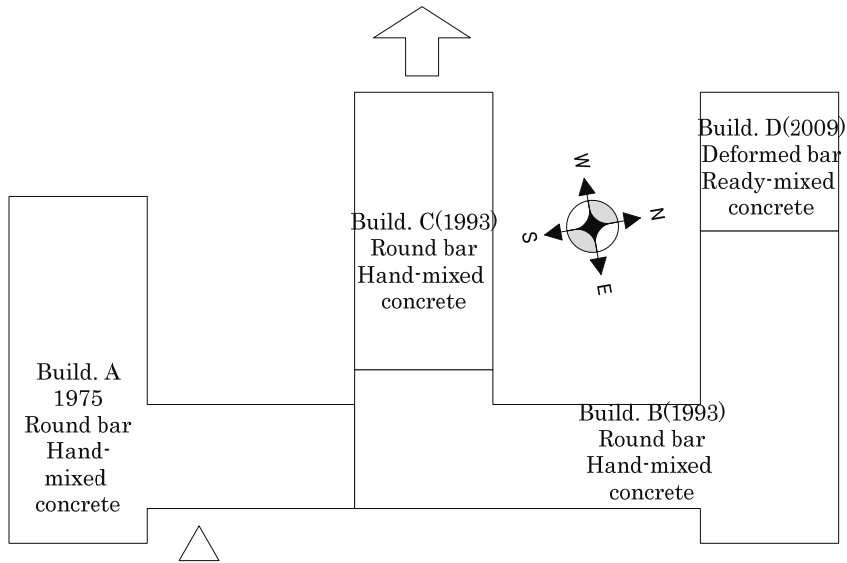

Figure 4 Plan of the main building



Photo 8 South-east side of the building



Photo 9 South side of Building C

Building C was severely damaged as shown in Photo 9. All columns yielded at the top and bottom ends of column and residual deformation was measured as about 7 degree. The residual gap between Building B and C at the second floor level is 30cm. Dimensions of all columns are the same, 200mm by 500mm. Bar arrangements in the columns were also investigated through cracks and with radar. There are four bars as main bar, of which diameter is 16mm, and diameter of hoop is 8mm with spacing of 200mm. The plan and column arrangement of building C is shown in Figure 5. Clear heights of columns, story heights, standing wall heights, and total height of the building are also shown in the Figureure.

Horizontal strengths of the columns, Q_u , are calculated as $\min(Q_{su}, Q_{mu})$ with Eq. (1) to Eq. (3), where $j: = (7/8) \cdot (D - 50)$, D is in mm, and concrete strength is assumed as 10 MPa.

Table 4 shows the calculated strengths. Only the column with D of 500mm and h of 1700mm is evaluated to fail in shear, although it showed flexural failure. Material tests are needed to discuss the failure mode. Story shear strength is calculated as 1006.01kN, $C_B=0.14$.

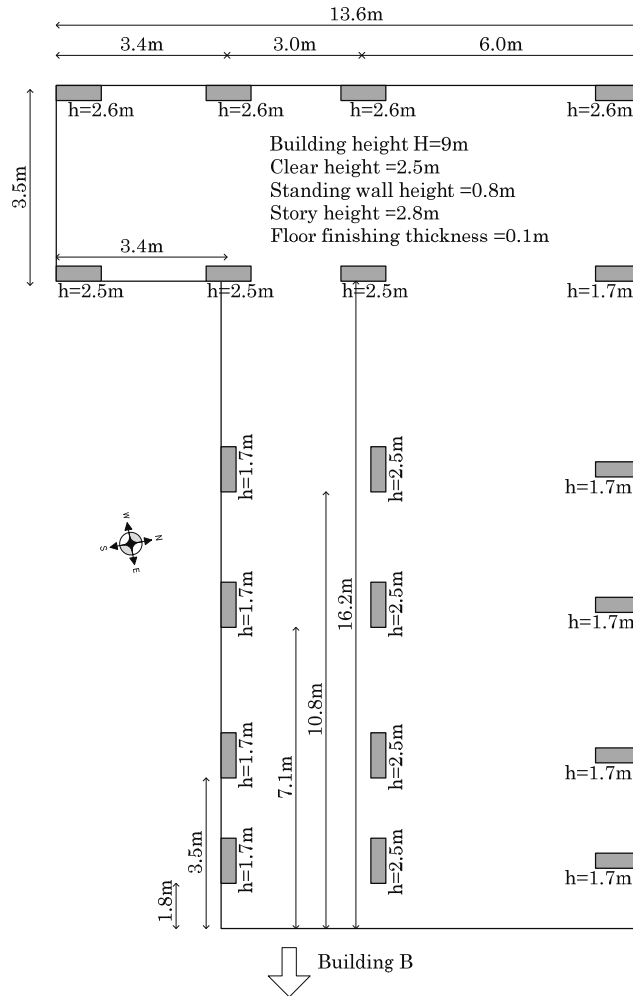

Figure 5 Floor plan and column arrangement of building C

Table 4 Strength of columns

b (mm)	200	200	500	500	500
D (mm)	500	500	200	200	200
h (mm)	1700	2500	2500	2600	1700
Num. of col.	4	4	3	4	5
Q_{mu} (kN)	84.7	78.07	30.12	23.83	44.61
Q_{su} (kN)	71.25	97.04	54.62	43.91	55.37
Q_{su}/Q_{mu}	0.84	1.24	1.81	1.84	1.24
Q_u (kN)	71.25	78.07	30.12	23.83	44.61
ΣQ_u (kN)	285	312.28	90.36	95.32	223.05

Other typical damages

An assessment of Bridge, Airport, Railway, Industrial structures and residential houses is presented in this part of the paper. The seismic motions did not cause any significant damage to bridges, airport terminals and railway, but the damage of some of the industrial structures and the residential houses were severe.

The type of bridges in damaged area was mainly simple concrete beam bridge (Photo 10(a)). Some bridges employed rubber bearings to have the effect of the seismic isolation as well as for consideration of thermal effects (Photo 10(b)). The use of airport terminal building was limited due to the damage of airport building. It should be mentioned the damage observed by our team was limited with the damages of non-structural members. On the other hand, the airplane service was completely recovered by utilization the new terminal building, which was taken into service right after the second earthquake (Nov.9th) (Photo 10(c)). The railway is normally used for international logistic service. The railway was available after the earthquake with no heavy damage (Photo 10(d)). The small scale industrial structures in the old industry zone were partially damaged. The structural systems of typical manufacturing structures were RC frames and infill wall of concrete blocks (Photo 11(a)). Photo 11(b) shows the total collapse of a manufacturing building. The adobe houses were also severely damaged (Photo 12(a)). The out of plane failure on the wall was observed (Photo 12(b)).



(a) Bridge with no significant damage



(b) Rubber bearing of photo(a)



(c) Damage of airport



(d) Railway with no significant damage



Photo 10 Damage of infrastructures



(a) Typical industrial structure



(b) Collapse of an industrial building

Photo 11 Damage of infrastructures



(a) Damage of adobe house



(b) Out of plane failure

Photo 12 Damage of houses

CONCLUDING REMARKS

Damages of several residential and public buildings due to 2011 VAN earthquake are presented in this paper. Most of severely damaged reinforced concrete buildings were built before 2000 with plain round bars as longitudinal reinforcement and hand-mixed concrete of low quality. Concrete core samples were taken from buildings, and the drawings are obtained and confirmed with the buildings. Further investigation is needed to find out the reason of the damage comparing with the buildings which suffered no damage.

ACKNOWLEDGMENTS

The investigation was conducted by the joint investigation team between Turkey and Japan. We would like to acknowledge the great help and support provided by Yuzuncu Yil University, Istanbul Technical University and people in Van city. Ph. D students and Technicians of Istanbul Technical University and Dr. Kutay Orakcal of Bogazici University also gave a great help to the investigation. Other than the logistical and financial supports of Istanbul Technical University and Yuzuncu Yil University, the encouragement of Rectors of both universities Prof. Dr. Muhammed Sahin and Prof. Dr. Peyami Battal is also acknowledged.

REFERENCES

The Japan Building Disaster Prevention Association (2001). *The standard of damage evaluation and the guidance of repair technology for the buildings hit by earthquakes.*, Tokyo, Japan. (in Japanese)