



RESIDUAL SEISMIC CAPACITY ESTIMATION OF RC FRAMES WITH CONCRETE BLOCK INFILL BASED ON THEIR CRACK WIDTHS

Yoshiaki NAKANO¹, Ho CHOI², and Noriyuki TAKAHASHI³

ABSTRACT: The objective of this study is to develop a post-earthquake seismic evaluation method for RC frames with unreinforced concrete block infill. For this purpose, full-scale, one-bay, single-story specimens are tested under cyclic loadings. In this paper, the relationship between measured residual crack width and residual seismic capacity is discussed experimentally and analytically, and reduction factors are proposed to estimate the residual seismic capacity based on the observed damage.

Key Words: residual seismic capacity, RC frame, concrete block infill, full-scale specimen, cyclic loading, crack width, seismic capacity reduction factor

INTRODUCTION

After an earthquake, major concerns to damaged buildings are their safety/risk to aftershocks, quantitative damage assessment to evaluate their residual seismic capacity and to identify necessary actions to be taken on the damaged buildings. Post-event damage evaluation is therefore essential for quick recovery of damaged communities as well as pre-event seismic evaluation and strengthening of vulnerable buildings.

The objective of this study is to develop a post-earthquake seismic evaluation method for RC frames with unreinforced concrete block (CB) infill. For this purpose, full-scale, one-bay, single-story specimens are tested under cyclic loadings. During the tests, residual crack widths, which can be found in damaged buildings as well as in laboratory tests, are carefully measured to estimate the residual seismic capacity from the observed damage. In this paper, the relationship between measured residual crack width and residual seismic capacity is discussed experimentally and analytically, and reduction factors are proposed to estimate the residual seismic capacity based on the observed damage.

OUTLINE OF EXPERIMENT

Figure 1 shows a standard design of Korean school buildings in the 1980s (The Ministry of Construction and Transportation, 2002). In this paper, 2 specimens representing a first or fourth story of 4 story RC school buildings are investigated. They are an infilled wall type 1 (IW1) assuming the first story and an infilled wall type 2 (IW2) assuming the fourth story. The design details of specimen IW1 are shown in Figure 2. Cyclic lateral loads are applied to each specimen through a loading beam tightly fastened to the specimen. For a loading history, peak drift angles of 0.1, 0.2, 0.4, 0.67, 1.0, and

¹ Professor, Department of Fundamental Engineering, Dr. of Engineering

² JSPS Postdoctoral Fellow, Dr. of Engineering

³ Research Associate, Department of Fundamental Engineering, Dr. of Engineering

2.0% are planned and 2.5 cycles for each peak drift are imposed to eliminate one-sided progressive failure (unsymmetric failure pattern in positive or negative loadings). A constant axial load of 1,440kN (720kN (4.0N/mm²) for each column) is applied to specimen IW1 while 360kN (180kN (1.0N/mm²) for each column) to specimen IW2.

Specimen IW1 has vertical and horizontal cracks in joint mortar between CB units and flexural cracks in RC columns at the first cycle of +0.1%. Shear cracks are then observed in both columns at the first cycle of +0.4%. Since the shear cracks rapidly open at -1.5% in the column bottom of compression side, the test is terminated after 1.5 cycles of 1.5% loading. Specimen IW2 has a crack pattern in both columns and wall, which is almost the same as that of specimen IW1. Although the strength deterioration is observed at the first cycle of +2.0%, a rapid increase in crack width is not found. Since the shear cracks rapidly open at +3.33% in the column bottom of compression side, the test is terminated. In specimen IW1, the maximum strength of 960 kN is recorded at the first cycle of +0.67% before the column longitudinal reinforcement yields. In specimen IW2, the column

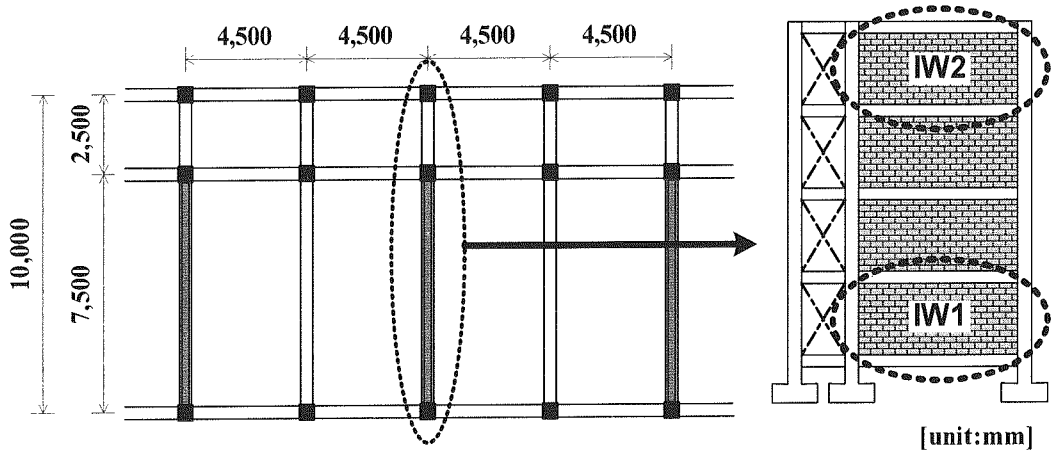

Figure 1: Standard design of Korean school buildings in the 1980s

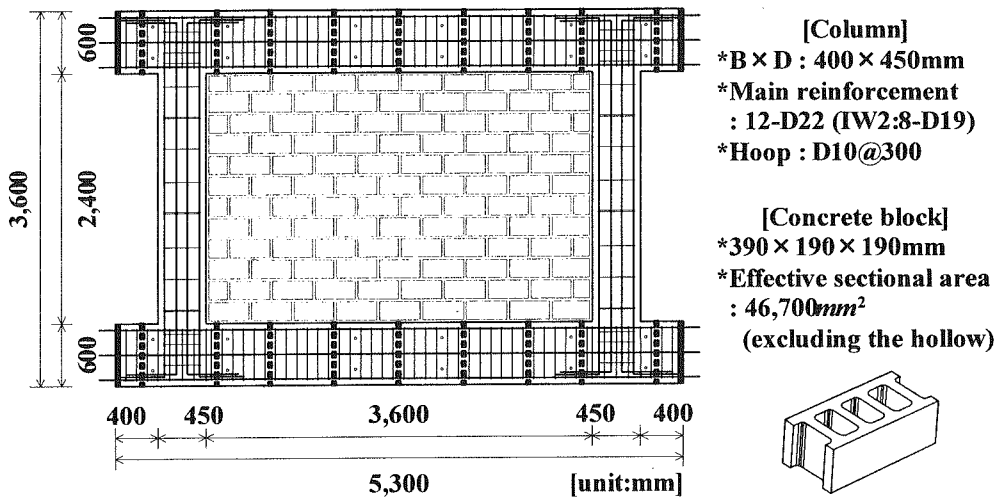

Figure 2: Details of specimen IW1

longitudinal reinforcement yields at the first cycle of +0.67%, and the maximum strength of 630 kN is recorded at the first cycle of +1.0%. The response of the specimens including crack patterns and their mechanism is discussed by Choi et al. (2006).

BASIC CONCEPT OF RESIDUAL SEISMIC CAPACITY EVALUATION

Figure 3 shows the basic concept employed in this study to evaluate the residual seismic capacity from residual crack widths observed in earthquake-damaged buildings. The seismic capacity is defined as the hysteretic energy that a structure can absorb during an earthquake, which is consistent with the basic concept found in the Japanese Standard for Seismic Evaluation of Existing RC Buildings (JBDPA, 2001 and 2005), since the procedure proposed herein to evaluate the residual seismic capacity is designed to be analogous to that of the Standard for existing (i.e., pre-earthquake damaged) buildings.

When the load-deformation relationship of a structure or members is investigated through loading tests prior to an earthquake and the response of the structure such as the peak deformation δ_p and/or the residual deformation δ_0 are given after an event, the residual seismic capacity $E_r (= E_T - E_d)$ can be calculated by the discrepancy between initial seismic capacity E_T prior to earthquake damage and dissipated seismic capacity E_d based on the load-deformation curve as shown in Figure 3(a).

Since the peak and residual deformations of buildings are, however, usually unknown after an earthquake unless they are instrumented, other information that can be surely obtained in the damaged buildings and quantitative data that can serve as a good estimator of the peak and/or residual deformation are therefore necessary to practically evaluate the residual seismic capacity. In this study, the residual crack width W_0 that can be quantitatively measured on damaged buildings is focused to estimate the residual deformation δ_0 as shown in Figure 3(b), and their W_0 - δ_0 relationships are experimentally and analytically studied. Once the W_0 - δ_0 relation and the δ_0 - E_r relation of typical buildings where damage is expected during an earthquake are clarified and the W_0 - E_r relation is then established, the residual seismic capacity E_r of a damaged building can be evaluated through the crack width W_0 that can be measured during a damage survey.

In the following sections, the W_0 - δ_0 relation (see Figure 3(b)) and the δ_0 - E_r relation (see Figure 3(a)) are investigated, respectively, to develop the W_0 - E_r relation (see Figure 3(c)) for RC frames with CB infill.

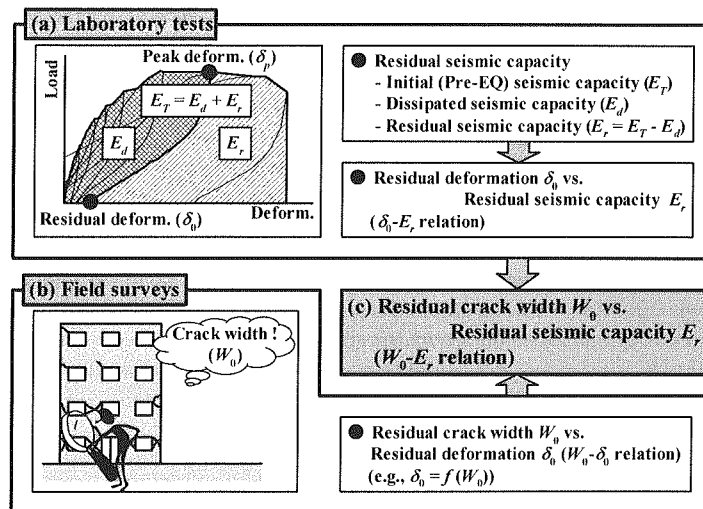

Figure 3: Basic concept of residual seismic capacity evaluation

RELATIONSHIP OF RESIDUAL CRACK WIDTH AND RESIDUAL DEFORMATION

Measurement of Crack Width

During the tests, crack widths of RC columns and CB walls are carefully measured at peak loads and unloaded stages. Figure 4 illustrates the measurement points on RC columns and CB walls made in this study.

The widths of flexural and shear cracks observed at the top and bottom of each column are visually measured with crack scales. Since crack widths are not necessarily uniform along the crack, its major width which is deemed to be largest along a crack is measured. It should also be noted that the width perpendicular to the crack is measured.

All visible cracks in the head joints found in stair-stepped diagonal cracks running through the CB wall are also measured to record the lateral dislocation of CB units (see (a) in Figure 4) while several cracks in the bed joints of one continued crack are measured to investigate a rotational behavior of wall (see (b) in Figure 4). In the following sections, crack widths measured in the head joints of CB walls of specimens IW1 and IW2 are investigated to understand the relationship between observed cracks and frame's behavior.

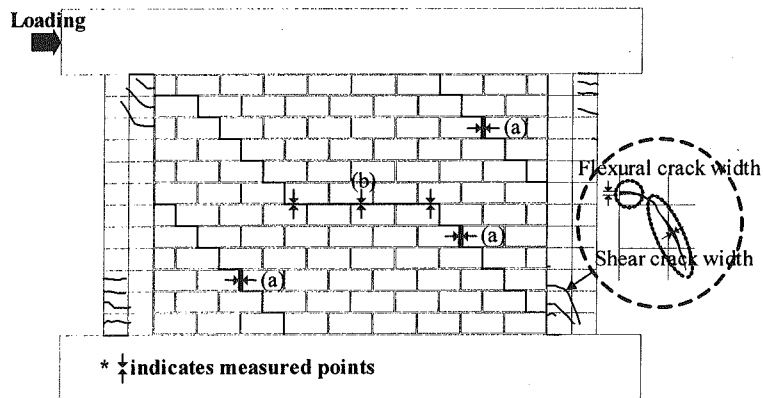

Figure 4: Schematic illustration of crack pattern and measurement points

Residual Crack Width of CB Wall

The residual deformation (δ_0), maximum residual crack widths and their total value of CB wall ($_{\max}W_0$ and $\Sigma_{\max}W_0$), and their ratios ($\Sigma_{\max}W_0/_{\max}W_0$, $_{\max}W_0/\delta_0$, and $\Sigma_{\max}W_0/\delta_0$), are plotted in Figure 5 for both specimens with respect to the peak drift angle (R_p) imposed in each loading cycle. In this figure, $_{\max}W_0$ is defined as the maximum residual crack width, as shown (a) in Figure 4, in the head joints of a continued stair-stepped diagonal crack. When the CB wall has more than one major stair-stepped diagonal crack, $_{\max}W_0$ can be found along each continued crack and the sum of $_{\max}W_0$ ($\Sigma_{\max}W_0$) is then calculated. As shown in the figure, the ratios $\Sigma_{\max}W_0/_{\max}W_0$, $_{\max}W_0/\delta_0$, and $\Sigma_{\max}W_0/\delta_0$ are stable over the deformations imposed during the tests, having an average of approximately 2.0, 0.125, and 0.25, respectively. As already discussed in detail by Choi et al. (2006), $\Sigma_{\max}W_0$ is highly correlated with shear deformation in RC columns but the overall deformation of a frame with long columns as is tested in this study is dominated by their flexural deformation up to around a peak drift angle of 1.0%, and the average of $\Sigma_{\max}W_0/\delta_0$ is therefore much smaller than 1.0 as shown in Figure 5(d).

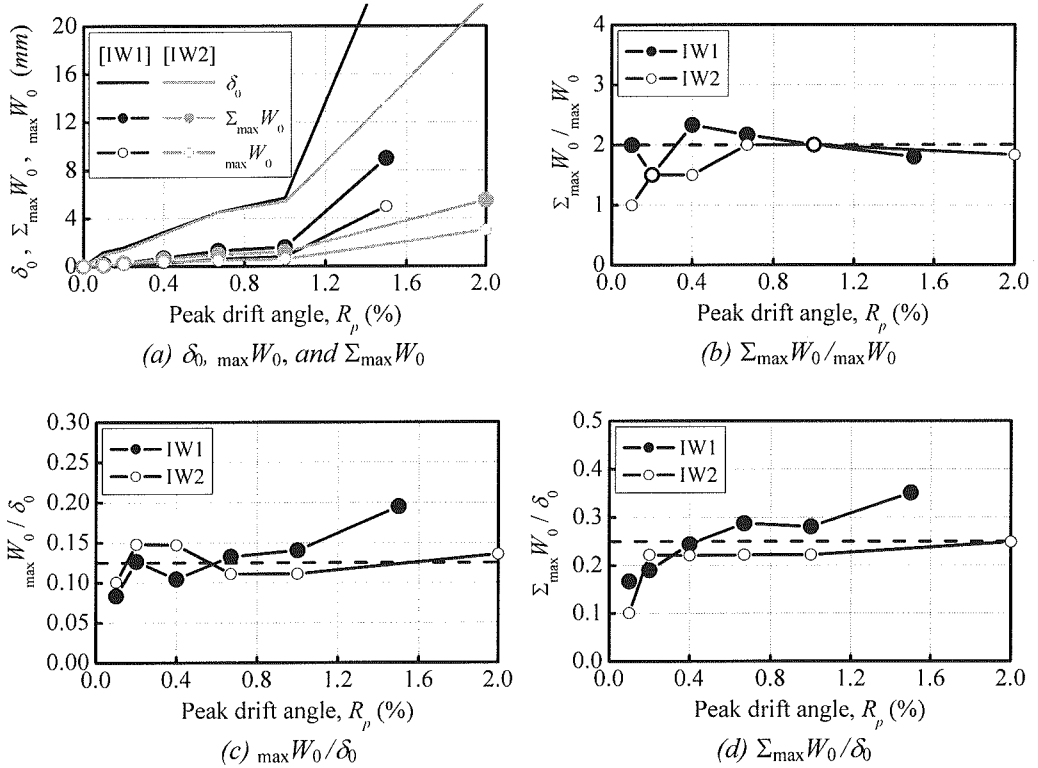

Figure 5: Relationship between residual crack width of CB wall $\max W_0$, residual deformation of frame δ_0 , and peak drift angle R_p

RELATIONSHIP OF RESIDUAL DEFORMATION AND RESIDUAL SEISMIC CAPACITY

In the previous section, the relationship of the residual crack width (W_0) of CB wall and the residual deformation (δ_0) of the specimens is discussed (see Figures 3(b) and 5). In this section, the relationship of the residual deformation (δ_0) and the residual seismic capacity (E_r) will be further investigated. For this purpose, the load-deformation curves obtained during the loading tests are approximated with a simplified model, and the seismic capacity reduction factor η is employed based on the model.

The load-deformation curve is first characterized by the following three basic points on the curve, the yield drift angle R_y , the maximum response drift angle R_p , and the ultimate drift angle R_u , where the drift angle is defined as the ratio of deformation to the column height ($h=2,400\text{mm}$) of specimens. In this study, R_y , R_p , and R_u are defined as shown below.

R_y : Drift angle when column longitudinal reinforcement yields.

(Note: The drift angle at the maximum strength is taken for IW1 because it preceded yielding of column reinforcement as stated earlier.)

R_p : Drift angle when a structure reaches its maximum response deformation.

R_u : Drift angle when the lateral load carrying capacity decreases to 80% of the peak load.

Figure 6 shows the characteristic points R_y and R_u of specimens IW1 and IW2 together with damage class determined considering its definition for RC members in the Guidelines for Post-Earthquake Damage

Evaluation and Rehabilitation of RC Buildings in Japan (2001) shown in Table 1 and Figure 7. The ultimate ductility factor μ of each specimen defined by R_u/R_y is approximately 2.0 and 3.0, respectively. When the structure's response has the peak drift angle R_p and the residual deformation angle R_0 , the dissipated hysteretic energy E_d normalized with respect to the column height can be calculated from the area enclosed by the curve $O-P-R_0$. The residual energy E_r , therefore, can be calculated from the remaining area shown hatched in Figure 6. Assuming that the hysteretic energy defined above corresponds to the seismic capacity, E_r represents the residual seismic capacity.

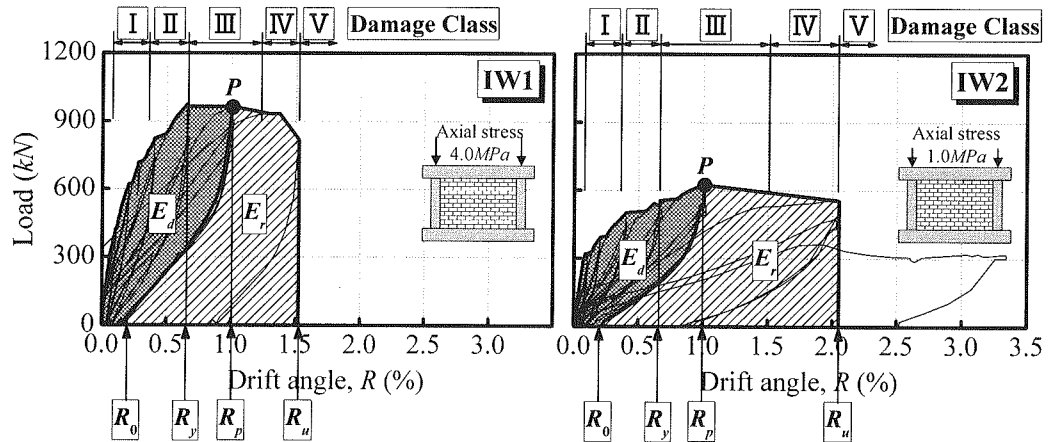
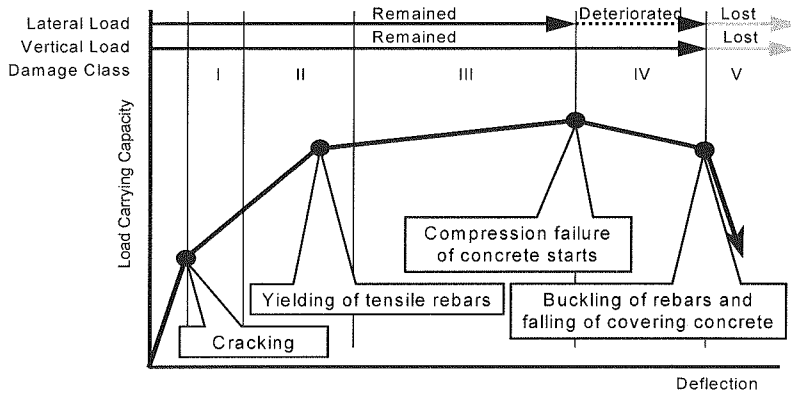

Figure 6: Load-drift angle relationship of specimens IW1 and IW2

Table 1: Damage Class Definition of RC Columns and Walls
(JBDPA, 2001 and Nakano et al., 2004)

Damage Class	Description of Damage
I	- Visible narrow cracks on concrete surface (Crack width is less than 0.2 mm)
II	- Visible clear cracks on concrete surface (Crack width is about 0.2 -1.0 mm)
III	- Local crush of concrete cover - Remarkable wide cracks (Crack width is about 1.0 - 2.0 mm)
IV	- Remarkable crush of concrete with exposed reinforcing bars - Spalling off of concrete cover (Crack width is more than 2.0 mm)
V	- Buckling of reinforcing bars - Cracks in core concrete - Visible vertical and/or lateral deformation in columns and/or walls - Visible settlement and/or leaning of the building



(a) Ductile Member

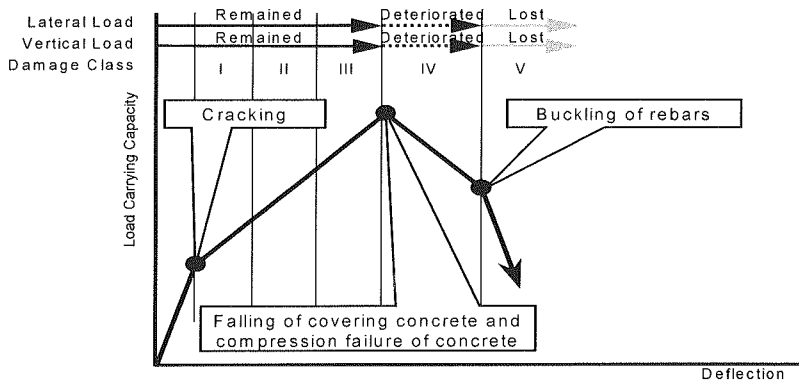

(b) Brittle Member

Figure 7: Schematic illustrations of damage class vs. load carrying capacity (JBDPA, 2001 and Nakano et al., 2004)

To facilitate to apply this procedure to hysteretic loops with different strength and ductility, a seismic capacity reduction factor η defined by the ratio of the residual capacity E_r to the initial capacity $E_T (=E_d+E_r)$ is then employed in this study. To find the R_0 - η relationship of a structure in a more general manner, the load-deformation curve is represented with a simplified hysteretic model with assumptions (1) through (3) described below. Figure 8 shows the simplified hysteretic model.

- (1) The Takeda model is employed for the basic hysteretic rule assuming (a) no hardening in post-yielding stiffness and (b) stiffness degradation factor α of 0.7 derived from the test results during unloading.
- (2) The load Q_{cr} and drift angle R_{cr} at cracking point are assumed $Q_y/3$ and $R_y/15$, respectively, where Q_y and R_y are the characteristic points at yielding.
- (3) The descending branch beyond the ultimate drift angle R_u , linearly decreases to $(\mu+1)R_y$ onto X-axis where the ductility factor μ is defined by R_u/R_y , which is analogous with the concept found in Maeda et al. (2000).

Figure 9 shows the relationship between the seismic capacity reduction factor η and the residual drift angle R_0 for different ultimate ductilities together with the test results. As described earlier, the

ductility factors of IW1 and IW2 are approximately 2.0 and 3.0, respectively, and Figure 9 shows good agreement of numerical simulations with test results.

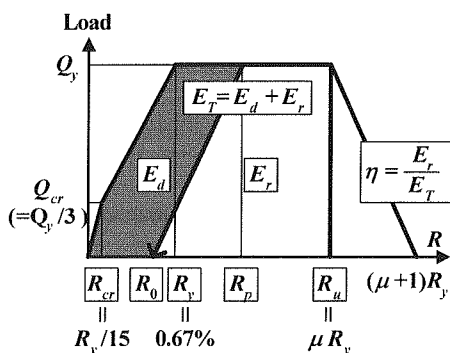

Figure 8: Simplified hysteretic model

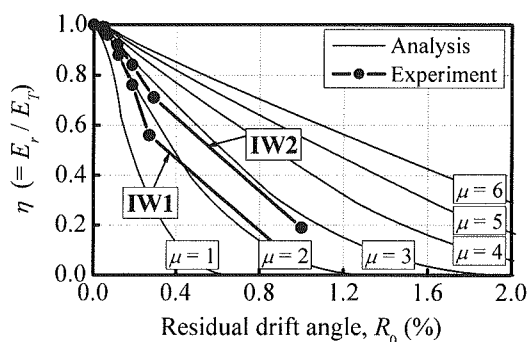

Figure 9: Relationship of R_0 and η

ESTIMATION OF RESIDUAL SEISMIC CAPACITY

Estimation of Residual Seismic Capacity by Residual Crack Width

As described earlier, the residual deformation δ_0 and the corresponding drift angle R_0 are usually unknown, and it would be therefore practical if the reduction factor η can be estimated from the evidence found in the damaged building. Since the ratio $\Sigma_{\max} W_0 / \max W_0$ has a stable relation and the value of $\max W_0 / \delta_0$ can be approximated to be 0.125 (=1/8) as is found in Figures 5(b) and (c), the residual drift angle R_0 can be written as:

$$R_0 = 8 \cdot \frac{\max W_0}{h_0} \quad (1)$$

Considering the relationship above and Figure 9, the reduction factor η can be estimated with respect to $\max W_0$ of CB wall as shown in Figure 10. It demonstrates that the numerical simulations agree well with the test results except for $\max W_0$ larger than 1.0mm for IW1. This discrepancy results from the evidence that the specimen IW1 had extensive shear cracks at the drift angle 1.5% during the final loading and the ratio $\max W_0 / \delta_0$ after unloading is much larger than 0.125 assumed in equation (1) as shown in Figure 5(c).

Estimation of Residual Seismic Capacity Corresponding to Damage Class

It should be noted that damage evaluation of buildings in the field is often made based on damage classification such as shown in Table 1 rather than direct and detailed description of measured digital data.

To facilitate to apply the relation found in Figure 10 in practice, the reduction factor η is plotted in Figure 11 with respect to the damage class I through V considering the relationship of peak drift angle and damage class shown in Figure 6 and equation (1), where data of specimen IW1 is used since serious damage is often found in the first story.

The results are summarized in Table 2 comparing factors specified in the Guidelines (JBDPA, 2001), where the proposed factors are determined as the average of experimental and estimated values

at the boundary of two adjacent damage classes in Figure 11. Note that the factors for damage classes IV and V are assumed 0 to conservatively evaluate the results. As shown in the table, the values of η determined in this study are almost the same as those for brittle RC column and wall in the Japanese Guidelines, since specimen IW1 is not ductile enough to maintain the peak load far beyond yielding.

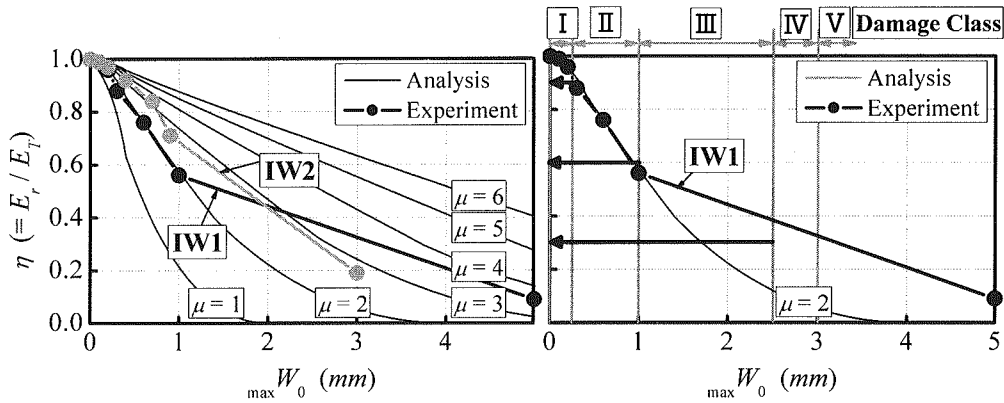

Figure 10: Relationship of η and $\max W_0$ of CB wall

Figure 11: Seismic capacity reduction factor η vs. damage class

Table 2: Seismic capacity reduction factor η corresponding to damage class

Damage Class	Proposed in this study for RC frames with CB infill	Specified in the Guidelines (JBDPA, 2001)	
		Brittle RC column / RC wall	Ductile RC column
I	0.90	0.95	0.95
II	0.60	0.60	0.75
III	0.30	0.30	0.50
IV	0.00	0.00	0.10
V	0.00	0.00	0.00

Finally, the residual seismic capacity E_r of RC frames with CB infill can be estimated from the following procedure.

- (1) Calculate the seismic capacity E_T of an original (i.e., pre-earthquake damaged) sub-assembly or frame with CB infill.
- (2) Classify its damage into one of five categories (class I to V) based on a damage survey.
- (3) Determine the seismic capacity reduction factor η based on the damage class made in (2) above. (see Table 2)
- (4) Calculate the residual seismic capacity E_r as ηE_T .

CONCLUSIONS

RC frames with concrete block (CB) infill representing typical school buildings in Korea are tested under cyclic loading to estimate the residual seismic capacity from residual crack widths measured on

CB walls. The results can be summarized as follows.

- (1) The ratio of maximum residual crack width of CB infill to residual deformation ($_{\max}W_0/\delta_0$) for specimens IW1 and IW2 approximately lies in the range of 0.1 to 0.15 with an average of 0.125. This result reveals that the residual deformation δ_0 that serves as a key parameter to evaluate the residual seismic capacity of a damaged RC building can be estimated from the maximum residual crack width $_{\max}W_0$ of CB infill measured during its damage survey.
- (2) The load-deformation curves obtained during the tests are then approximated with a simplified hysteretic model, and the relationship of the residual drift angle R_0 and the residual seismic capacity reduction factor η is established based on the model. The results show good agreement with test results, which imply that the procedure proposed herein can be applied to estimate the residual seismic capacity of RC frames with CB infill having different strength and ductility.
- (3) Considering the results stated in (1) and (2) above, the relationship of $_{\max}W_0$ and η is established. This relationship is further extended to practically estimate η from damage classification that may be applied to categorize damage of members primarily considering observed evidence including crack width during damage surveys.
- (4) The values of η proposed in this study for RC frames with CB infill corresponding to each damage class are found almost the same as those for brittle RC column and wall specified in the Japanese Guidelines for Post-Earthquake Damage Evaluation, since the proposed values are based on data of specimen IW1, which is not ductile enough to maintain the peak load far beyond yielding.

ACKNOWLEDGMENT

The research reported herein was performed in cooperation with Professor Waon-Ho Yi of the Kwangwoon University and Dr. Sang-Hoon Oh of RIST (Research Institute of Industrial Science and Technology) in Korea. The authors express their deepest gratitude to all these supports without which the test could not be accomplished.

REFERENCES

- Choi, H., Nakano, Y. and Takahashi, N. (2006). "Residual Seismic Capacity of RC Frames with Unreinforced Block Wall based on their Crack Widths." *Bulletin of Earthquake Resistant Structure Research Center*, Institute of Industrial Science, The University of Tokyo, No.39, 33-48.
- JBDPA/The Japan Building Disaster Prevention Association (1977, 1990, and 2001 (in Japanese), and 2005 (in English)). Standard for Seismic Evaluation of Existing Reinforced Concrete Buildings.
- JBDPA/The Japan Building Disaster Prevention Association (2001). Guidelines for Post-Earthquake Damage Evaluation and Rehabilitation (in Japanese).
- Maeda, M., Bunno, M., and Nataga, M. (2000). "A Study on the Damage Class Estimation of RC Buildings Based on Residual Seismic Capacity of Members." *Proceedings of the Japan Concrete Institute*, Vol. 22, No. 3, 1447-1452 (in Japanese).
- Nakano, Y., Maeda, M., Kuramoto, H., and Murakami, M. (2004). Guideline for Post-Earthquake Damage Evaluation and Rehabilitation of RC Buildings in Japan. *13th World Conference on Earthquake Engineering*, Vancouver, B.C., Canada (CD-ROM).
- The Ministry of Construction and Transportation (2002). A Study on the Seismic Evaluation and Retrofit of Low-Rise RC Buildings in Korea, 113-155 (in Korean).